

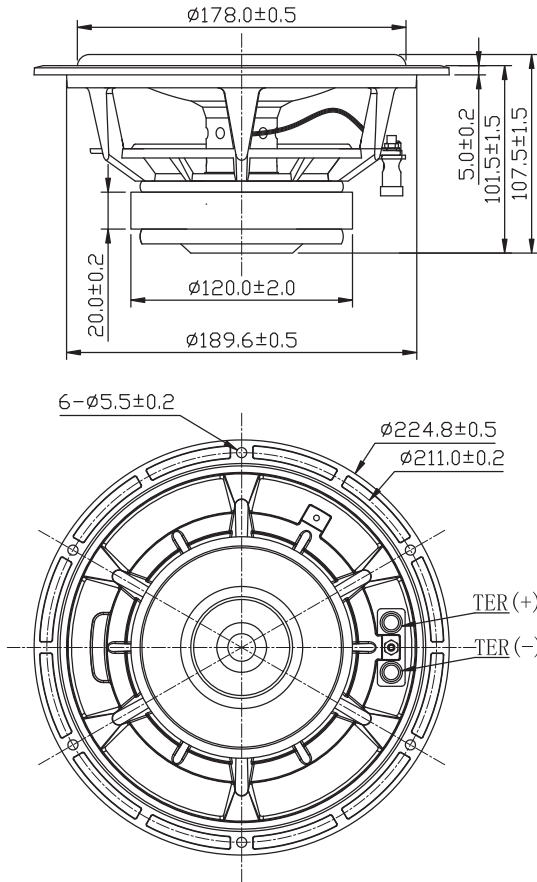

8" Signature Series Woofer 100W Driver 4 Ohm

SIG225-4



PARAMETERS

Impedance	4 ohms
Re	3.9 ohms
Le	0.49 mH @ 1kHz
Fs	40 Hz
Qms	8.87
Qes	0.45
Qts	0.43
Mms	36.9g
Cms	0.43 mm/N
Sd	220.8 cm ²
Vd	132.5 cm ³
BL	9.0 Tm
Vas	29.7 liters
Xmax	6 mm*
VC Diameter	39 mm
SPL	91.4 @ 2.83V/1m
RMS Power Handling	100 watts
Usable Frequency Range	39 - 4,500 Hz

*at 70% BI (Klippel verified)

IMPEDANCE/PHASE

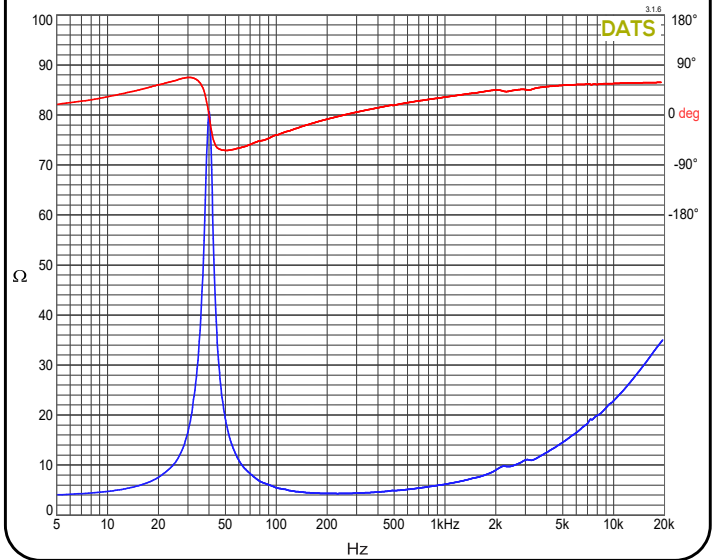

FEATURES

- Extensive Klippel LMP and LSI testing to optimize BI symmetry and parameters
- Indexed cone/surround junction for smooth transition/frequency response
- Polyimide formers for improved mechanical damping smooth frequency response
- One piece concave black anodized aluminum cone
- Vented former and elevated spider for improved air flow
- Open aluminum cast frame for improved heat dissipation
- Countersunk stainless steel magnet badging for long time aesthetics

FREQUENCY RESPONSE

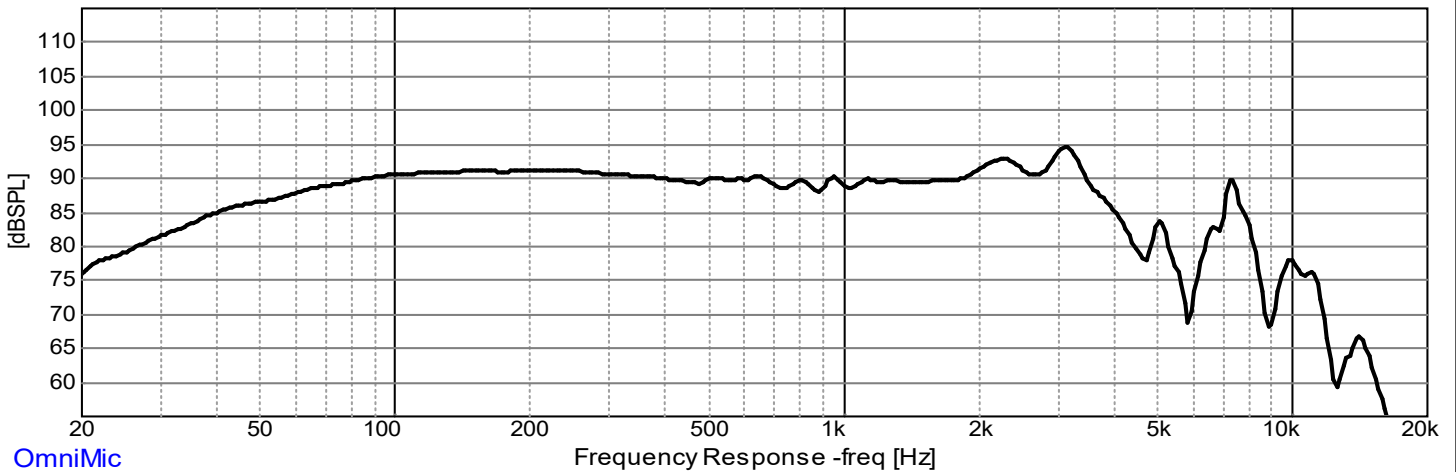

Note: 1/24th octave smoothing - near field response included in graph below 450 Hz.