

# 70V RACKMOUNT PA MIXER-AMPLIFIER

User Manual

Model: DA350D / DA650D

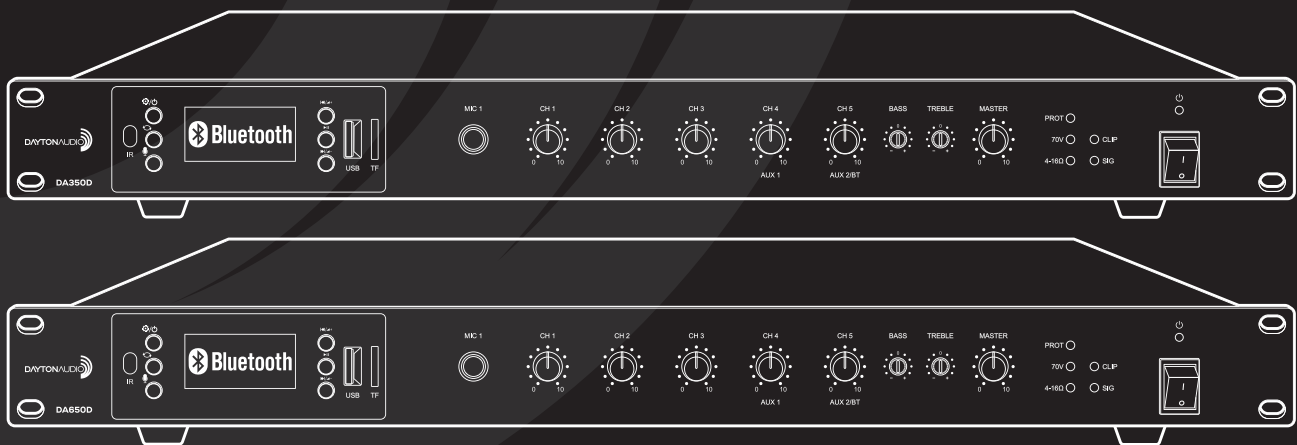

## Safety Precautions

- Be sure to read the instructions in this section carefully before use.
- Make sure to observe the instructions in this manual as the conventions of safety symbols and messages regarded and very important precautions are included.
- We also recommend you keep this instruction manual handy for future reference.

### Safety Symbol and Message Conventions

Safety symbols and messages described below are used in this manual to prevent bodily injury and property damage which could result from mishandling. Before operating your product, read this manual first and understand the safety symbols and messages so you are thoroughly aware of the potential safety



### WARNING

Indicates a potentially hazardous situation which, if mishandled, could result in death or serious personal injury.



### CAUTION

Indicates a potentially hazardous situation which, if mishandled, could result in moderate or minor personal injury, and/or property damage.



### WARNING

#### When Installing the Unit

- Do not expose the unit to rain or an environment where it may be splashed by water or other liquids, as doing so may result in fire or electric shock.
- Use the unit only with the voltage specified on the unit. Using a voltage higher than that which is specified may result in fire or electric shock.
- Do not cut, kink, otherwise damage nor modify the power supply cord. In addition, avoid using the power cord in close proximity to heaters, and never place heavy objects -- including the unit itself -- on the power cord, as doing so may result in fire or electric shock.
- Be sure to replace the unit's terminal cover after connection completion. Because high voltage is applied to the speaker terminals, never touch these terminals to avoid electric shock.
- Be sure to ground to the safety ground (earth) terminal to avoid electric shock. Never ground to a gas pipe as a catastrophic disaster may result.
- Avoid installing or mounting the unit in unstable locations, such as on a rickety table or a slanted surface. Doing so may result in the unit falling down, causing personal injury and/or property damage.

#### When the Unit is in Use

- Should the following irregularity be found during use, immediately switch off the power, disconnect the power supply plug from the AC outlet and contact your nearest Dayton Audio dealer. Make no further attempt to operate the unit in this condition as this may cause fire or electric shock.
  - If you detect smoke or a strange smell coming from the unit.
  - If water or any metallic object gets into the unit
  - If the unit falls, or the unit case breaks
  - If the power supply cord is damaged (exposure of the core, disconnection, etc.)
  - If it is malfunctioning (no tone sounds.)
- To prevent a fire or electric shock, never open nor remove the unit case as there are high voltage components inside the unit. Refer all servicing to your nearest Dayton Audio dealer.
- Do not place cups, bowls, or other containers of liquid or metallic objects on top of the unit. If they accidentally spill into the unit, this may cause a fire or electric shock.
- Do not insert nor drop metallic objects or flammable materials in the ventilation slots of the unit's cover, as this may result in fire or electric shock.

## CAUTION

### When Installing the Unit

- Never plug in nor remove the power supply plug with wet hands, as doing so may cause electric shock.
- When unplugging the power supply cord, be sure to grasp the power supply plug; never pull on the cord itself. Operating the unit with a damaged power supply cord may cause a fire or electric shock.
- When moving the unit, be sure to remove its power supply cord from the wall outlet. Moving the unit with the power cord connected to the outlet may cause damage to the power cord, resulting in fire or electric shock. When removing the power cord, be sure to hold its plug to pull.
- Do not block the ventilation slots in the unit's cover. Doing so may cause heat to build up inside the unit and result in fire.
- Avoid installing the unit in humid or dusty locations, in locations exposed to the direct sunlight, near the heaters, or in locations generating sooty smoke or steam as doing otherwise may result in fire or electric shock.

### When the Unit is in Use

- Do not place heavy objects on the unit as this may cause it to fall or break which may result in personal injury and/or property damage. In addition, the object itself may fall off and cause injury and/or damage.
- Make sure that the volume control is set to minimum position before power is switched on. Loud noise produced at high volume when power is switched on can impair hearing.
- Do not operate the unit for an extended period of time with the sound distorting. This is an indication of a malfunction, which in turn can cause heat to generate and result in a fire.
- Contact your Dayton Audio dealer as to the cleaning. If dust is allowed to accumulate in the unit over a long period of time, a fire or damage to the unit may result.
- If dust accumulates on the power supply plug or in the wall AC outlet, a fire may result. Clean it periodically. In addition, insert the plug in the wall outlet securely.
- Switch off the power, and unplug the power supply plug from the AC outlet for safety purposes when cleaning or leaving the unit unused for 10 days or more. Doing otherwise may cause a fire or electric shock.

Due to product upgrades, some of the features and specifications in the user manual do not match the actual functions. Sorry for any inconvenience and thanks for your kind understanding!

## Welcome

The Dayton Audio DA series of mixer amplifiers are designed specifically for professional and commercial applications. Complete with a built in media player, Bluetooth receiver, and mixer the DA Class-D series of amplifiers make it easy to add audio to any home or business.

## Contents

<b>Safety Precautions</b> .....	<b>2-3</b>
<b>Welcome</b> .....	<b>4</b>
Features .....	4
What's in the Box? .....	4
<b>Control and Functions</b> .....	<b>5</b>
Front Panel .....	5
Rear Panel .....	5
<b>Setup</b> .....	<b>6</b>
Unpacking Your Amplifier .....	6
<b>Installing Your Amplifier</b> .....	<b>6-7</b>
Ensuring Proper Cooling .....	6
Input Wiring .....	7
Output Wiring .....	7
Connecting to AC Mains .....	7
<b>Operation</b> .....	<b>8-10</b>
Media Player .....	8
Remote .....	9
Bluetooth Pairing .....	10
Input Level Control .....	10
VOX Function .....	10
Priority and EMC Muting .....	10
Output Level Control .....	10
Aux Output .....	10
<b>Troubleshooting</b> .....	<b>11</b>
<b>Specifications</b> .....	<b>12</b>
<b>Dimensional Diagram</b> .....	<b>13</b>
<b>Block Diagram</b> .....	<b>14</b>
<b>Warranty</b> .....	<b>15</b>

## Features

- High power 70V amp for driving large 70V systems
- Class D amplifier stays cool and uses less power
- Compact 1U enclosure takes up less space in equipment racks
- Built In Bluetooth receiver and Media player for true All-In-One operation
- Switchable Mic/Line inputs for universal connectivity
- Capable of 4-8ohm operation when switched in correct mode

## What's in the Box?

- DA Class D Mixer Amplifier
- Remote Control
- AC Power Cable
- Five Euroblock Connectors (installed on unit)
- User Manual

# Controls And Functions

## Front Panel

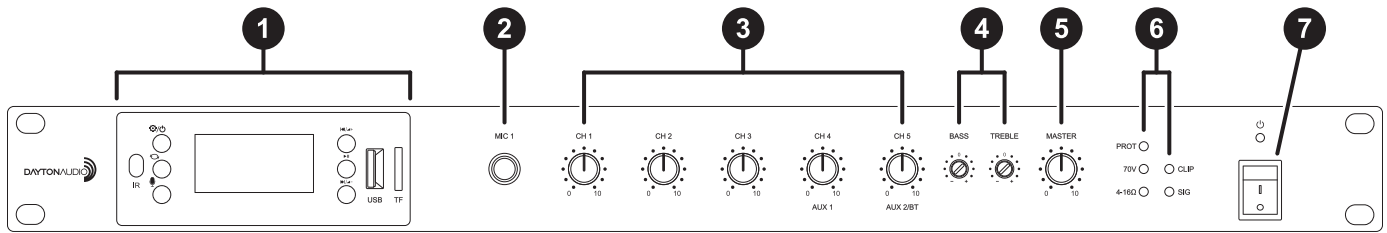

1. Media Player
2. Mic 1 Unbalanced Input
3. Input Level Controls
4. Tone Control
5. Output Volume Control
6. Status Indicators
7. Power Switch

## Rear Panel

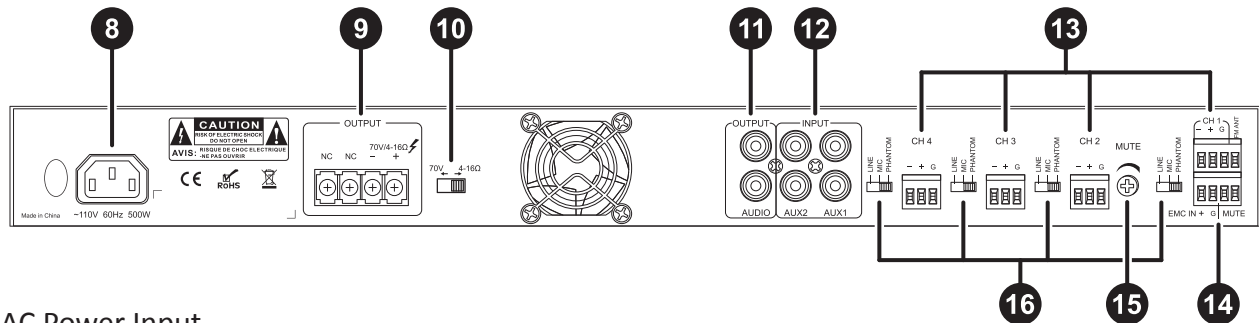

8. AC Power Input
9. Amplifier Output
10. 70V/ Low-Z Speaker Output Switch
11. Line Output
12. Line Inputs
13. Mic/Line Input Connector
14. Priority Muting Interface Connector
15. VOX Control
16. Line/Mic/+48V Selection Switch

## Setup

### Unpacking Your Amplifier

Before installing your amplifier, please unpack and inspect it for any damage that might have occurred during shipment. Verify that all accessories are included in the box. If you notice damage or that parts are missing, please contact Dayton Audio for assistance.

**Warning:** Please read and observe the safety instructions at the beginning of the manual before setting up your amplifier

### Installing Your Amplifier

#### Ensuring Proper cooling

Be sure to keep all sides of the product clear and free of objects that may obstruct the air flow and prevent proper cooling of the amplifier. It is best to keep 4" of clearance on all sides.

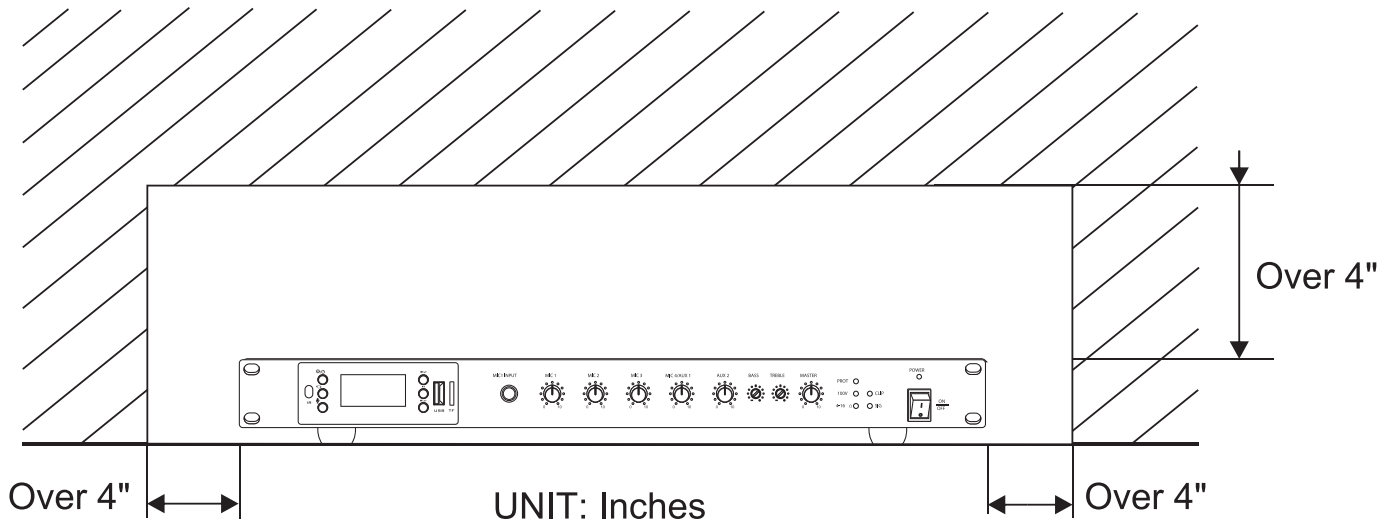

## Input Wiring

Using high quality balanced 22-24 gauge cable, connect to the balanced inputs by using the included Phoenix style connectors. Shielded cable will provide the best results. Unbalanced or unshielded cable may result in RF noise or a Hum in the input signal.

You can also connect devices such as CD players, computers, or streaming devices using the available Stereo RCA connections. The stereo signal will be summed to mono for both the amplifier and line level outputs

**Note:** Do not use the RCA input on a single channel at the same time as the Phoenix style input.

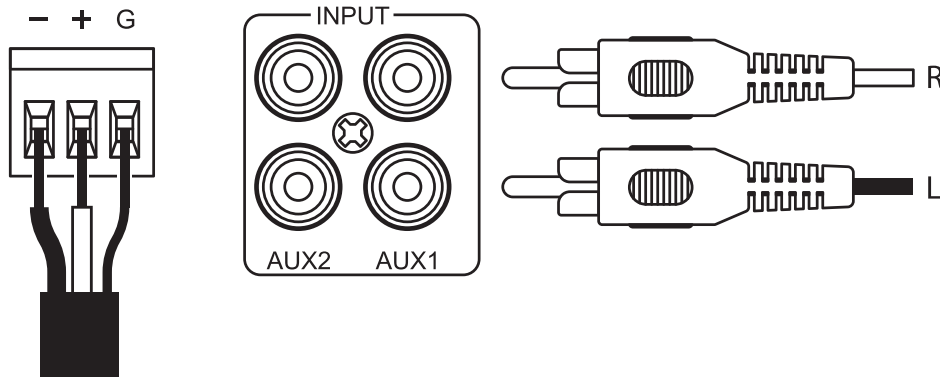

## Output Wiring

Connect passive speakers to the output terminals on the rear of the amplifier. To avoid damage to the amplifier or speakers, be sure the 70V/4-16Ω is in the correct position for your system.

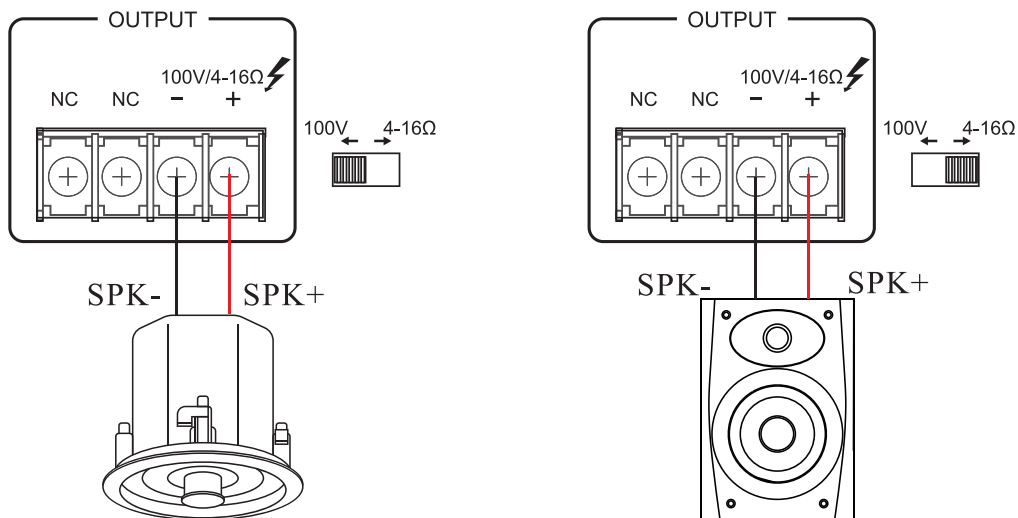

It is recommended that high quality, heavy gauge, two conductor twisted speaker cable is used when connecting your loudspeakers. 14-16 AWG wire will work in most applications

## Connecting to AC Mains

Connect your amplifier to mains power using the supplied AC power cable to a grounded outlet. The third prong of the AC power cable is important and necessary for safe operation of your amplifier. Do not attempt to disable the ground connection.

## Operation

### Media Player

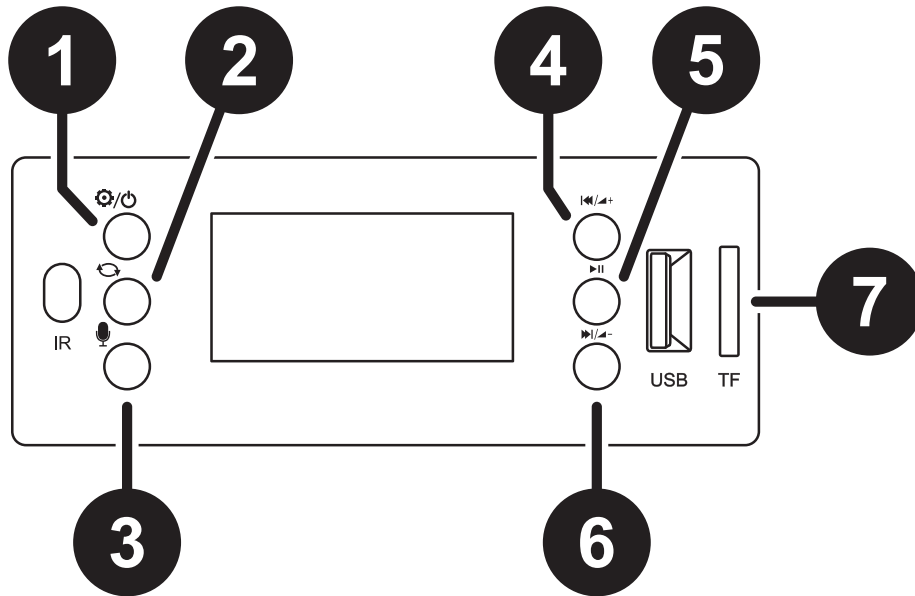

1. **Mode/Power**– Press to cycle between FM, USB/Micro SD card, and Bluetooth inputs. Press and hold to turn the media player on and off. (This does not turn the amplifier off)
2. **Repeat** – Cycle between different playback modes (Repeat one, repeat all, Random, Repeat Folder)
3. **Record** – (Currently Inoperable)
4. **Previous Track/ Volume Down** – Press to switch to the previous track when playing from USB or Bluetooth, This controls the volume when in line-input mode.
5. **Play/Pause** – Press to pause the track while playing in Bluetooth or USB Mode, press again to resume playing the same track.
6. **Next Track/ Volume Up** - Press to switch to the next track when playing from USB or Bluetooth, This controls the volume when in line-input mode.
7. **USB/SD card reader** – The media player can read MP3/ WAV/ WMA/ AEC and FLAC files. Do not use a USB drive or Micro SD card larger than 32GB.



## Remote

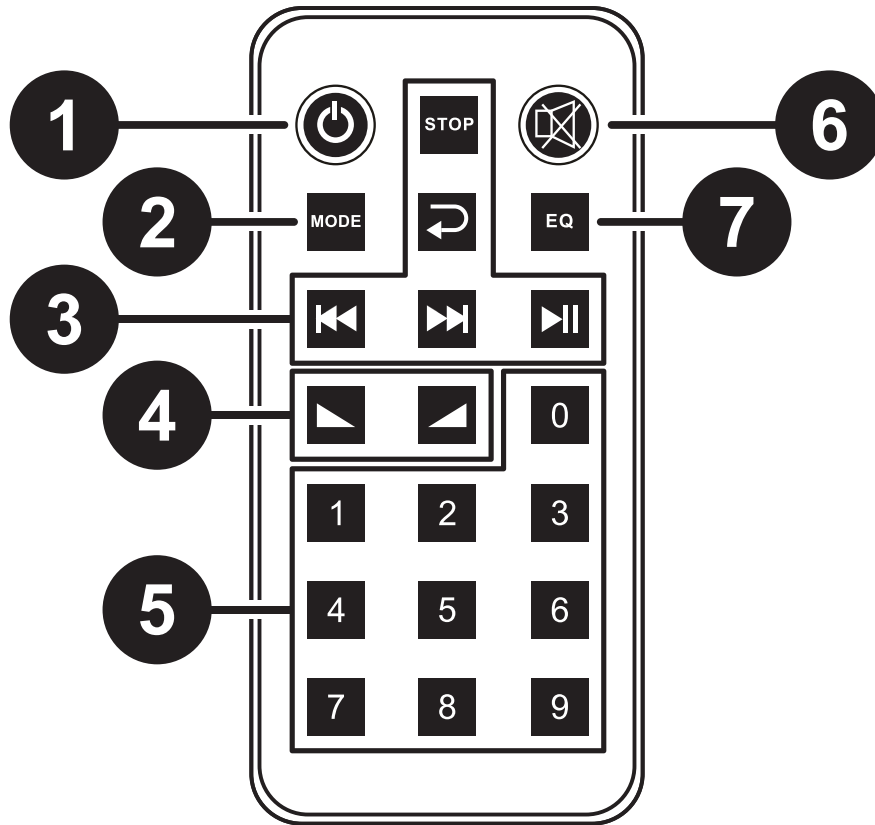

### 1. Power

Will turn the media player on and off

### 2. Input Mode Selection

Will cycle through the various input modes

### 3. Track Transport Controls

Control the playback of the media player



start/pause the current song



skip forward to the next song.



skip backward to the beginning of the current song or the previous song



control the repeat setting



completely stop all playback

### 4. Volume +/-

Control the volume of the media player.

### 5. 0-9 Number buttons

### 6. EQ

Cycle through the different EQ settings

## Bluetooth Pairing

To pair a Bluetooth device to the built in media player, press and hold the mode button to activate pairing mode and search for “BP10\_BT” on your Bluetooth device.

## Input Level Control

Each input channel has the ability to accept line and microphone signals and can also supply phantom power to microphones when necessary.

Set the level control switch on each channel according to the source that is connected. Improperly setting this switch could result in the signal being too quiet or being distorted.



## VOX Function

Audio activated ducking is a useful feature that can mute other channels when audio is present on Channel 1. Adjusting the “Mute” knob on the rear of the amplifier will control how much audio is required to mute the other inputs. Turning “mute” all the way down (counterclockwise) will disable this function.

MUTE



## Priority and EMC Muting

Channel 1 can also be used as a priority channel. All other channels can be immediately muted when pins 3 and 4 on the priority muting interface connector are shorted using an external switch or the button of a dedicated paging microphone

The Amplifier also has the ability to accept Emergency Control Muting (EMC) from capable safety systems, muting all output from the amplifier. This feature can be activated by shorting pins 1 and 3 on the priority muting interface connector.

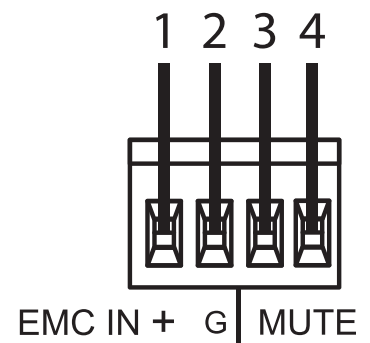

## Output Level Control

Set the main volume output with the Master Volume knob. Avoid overpowering the connected speakers as too much power can distort and damage loudspeakers over time. The built in limiter and protection circuit acts as a safeguard against clipping and short circuits.

## Aux Output

The Aux audio output is a mono mix of all signals. The master volume output and tone controls will have no affect on the aux output signal.

## Troubleshooting:

Problem	Cause	Solution
The unit fails to turn on	The power cable is not connected properly	Check to make sure both ends of the power cable are connected properly.
	Protection circuit has been activated	Turn the amplifier off and check that your speaker wires are not shorting out. If this problem persists please contact Dayton Audio for customer support.
The unit turns off suddenly	There is a short in the connected speaker wire	Examine the speaker wire for any damage. Do not use any cable that has exposed wire.
	Speaker malfunctioning	Disconnect the speakers one at a time to see if the issue is caused by the speakers or the amplifier. If the problem persists with all speakers please contact Dayton Audio customer support.
No sound	The master volume is turned down	Turn the master volume knob up to the desired level.
	TEL or EMC circuit is activated	Check external equipment to verify it is not activating the circuit.
	Incorrect cable connections	Double check that the device that you are trying to listen to is connected to the correct input.
Low volume	Volume on the playback device is turned down	Verify that any volume control on your phone, computer, or connected playback device is turned up.
	The mixer channel input is turned down	Turn the channel volume knob up to the desired level.
	70v/Low-Z switch set incorrectly	Select the mode that is appropriate for your system.
The sound output lacks bass	The speakers polarity is reversed	Double check the speaker connections, ensuring that the + and - terminals are connected properly on both speakers. (p.7)
	The bass knob is turned down	Ensure that the "BASS" control knob is not turned down all the way.
Sound is distorted	The input signal is too high	Verify that any volume control on your phone, computer, or connected playback device is not set excessively high.
	Master volume is too high	Verify that the master volume is not set excessively high.
	Mic/Line switch is set improperly	Select the mode that is appropriate for your input.

## Specifications

	DA350D	DA650D
<b>Max Output Power Per Channel</b>	700@4ohm 350@8ohm	1300@4ohm 650@8ohm
<b>Continuous Power Per Channel</b>	410@4ohm 205@8ohm	580@4ohm 290@8ohm
<b>Number of Input channels</b>	7	
<b>Number of Output Channels</b>	1	
<b>Line Output Level</b>	1Vrms into 10kohm	
<b>Input Sensitivity</b> to obtain full rated power at 8ohm	Mic Input: 4.2 mV Line Input: 250 mV	
<b>Frequency Response</b> (measured at 2.83Vrms into 4ohm load impedance)	4/8 Ohm Output: 30 Hz - 18 kHz +/- 1.5dB 70V/100V Outputs: 80Hz - 18kHz +/- 3db Line Out: 20Hz - 20kHz +/-1dB	
<b>Total Harmonic Distortion (THD)</b> 1k sine at rated output into a 4 ohm load	Power Amp Output: <= 0.2% Line Output: <0.02%	
<b>Signal To Noise Ratio</b> (Ref. Rated Power, No input, maximum master volume. A-weighted)	Mic Input: 71 dB Aux Input: 86.8 dB	
<b>Input Impedance</b> (nominal)	Mic Input: 214Ω Line: 22kΩ (balanced) RCA Input: 4.7kΩ	
<b>Phantom Power</b>	48 VDC	
<b>Channel Crosstalk</b> (reference rated power, volume at mid position, 1kHz)	N\A	
<b>AC Power Requirement</b>	110~120V, 60 Hz	
<b>Minimum Load impedance</b> Low Impdance Output 70V Output	3.6Ω	3.6Ω
<b>Protection Mode</b>	Overheat, Overcurrent, & Short Circuit Protection	
<b>Operating Temperature</b>	41°F to 104°F (5°C to 40°C) @ 95% R.H. (non-condensing)	
<b>Storage Temperature</b>	-4°F to 158° F (-20°C to 70°C)	
<b>Power Consumption</b>	500W	850W
<b>Weight</b>	10.14 lb (4.6 Kg)	10.58 lb (4.8 Kg)
<b>Dimensions</b>	19 x 12-1/2 x 1-3/4 in. (484 x 315 x 44 mm)	

All specifications are accurate at the time of printing.  
Dayton Audio reserves the right to make improvements without notice.

# Dimensional Diagram

UNIT:mm

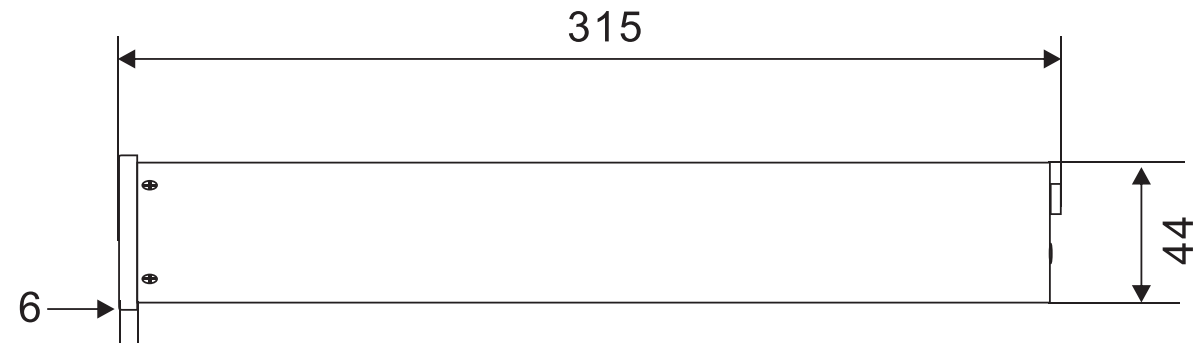
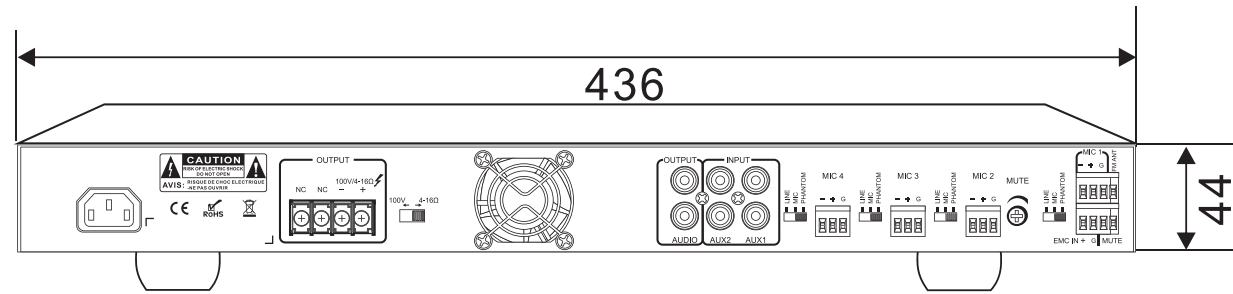
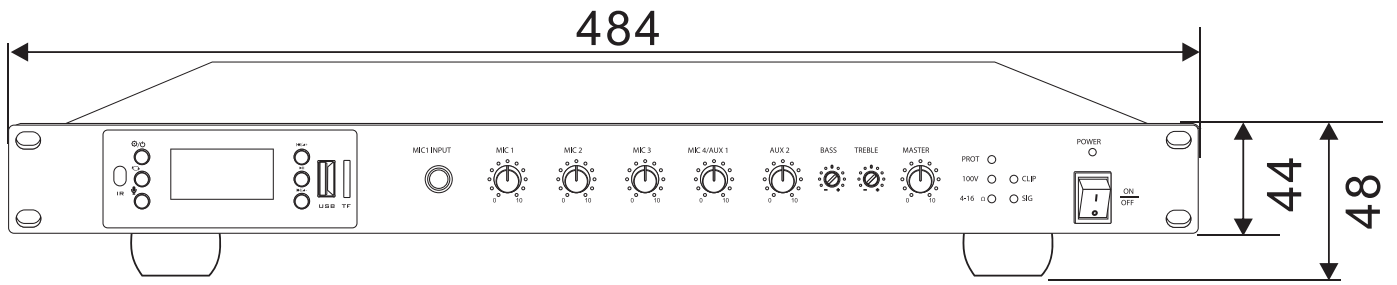

# Block Diagram

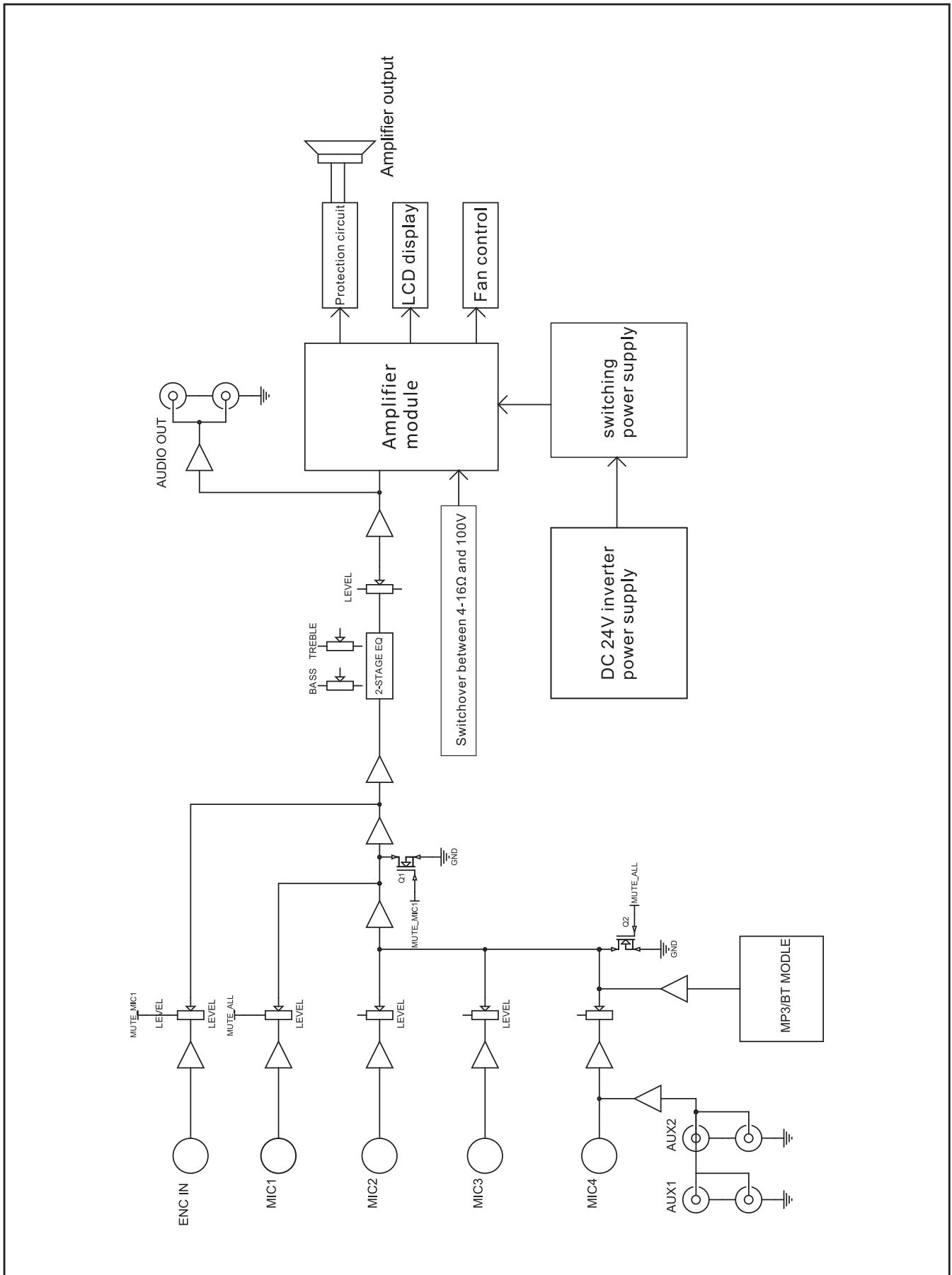

## Warranty

Dayton Audio products are warranted to be free of all defects in material and workmanship for 5 YEARS from the date of purchase from an authorized Dayton Audio dealer. This warranty and all rights provided are limited to the original owner and are non-transferable. Responsibility is limited to replacement or repair as set forth in this warranty statement.

Should a product require warranty service during this period, Dayton Audio will repair or replace without charge, any part or product proving defective in material or workmanship. All warranty repairs and service must be performed by an authorized Dayton Audio technician or service facility. The use of non-authorized repair services renders this warranty null and void, and any charges relating to non-authorized repair are the responsibility of the product owner.

All expenses (except return shipping costs) related to replacing or repairing a defective part or product under this warranty shall be assumed by Dayton Audio. Dayton Audio reserves the right to replace defective product with a new or factory reconditioned unit.

For more information and to register your new Dayton Audio device visit [daytonaudio.com](http://daytonaudio.com).

Purchased on: \_\_\_\_\_



[daytonaudio.com](http://daytonaudio.com)  
tel + 937.743.8248  
[info@daytonaudio.com](mailto:info@daytonaudio.com)

705 Pleasant Valley Dr.  
Springboro, OH 45066  
USA