



10" 100W LOW-PROFILE POWERED SUBWOOFER

Model: SUB-1000L User Manual



Thank you for purchasing the Dayton Audio® SUB-1000L 10" Powered Subwoofer. It is the perfect addition to any home theater system where space is at a premium. This powered sub features a low-profile bass reflex enclosure, providing enhanced low frequencies from a design less than 6" in height. It also utilizes a long throw 10" woofer and up to 100 watts of house shaking power. This compact sub is finished in a non-obtrusive black veneer that will complement any decor.

Hookup

1. Line Level Inputs

The line level inputs are used to connect pre-out or preamplifier outputs directly to the subwoofer amplifier's internal crossover. These inputs are summed to mono. This is the preferred way to connect the subwoofer amplifier. If you have a mono line level signal from a "Pro Logic" or "Dolby Digital" receiver use the right "red" input. **Note: If a LFE mono output is connected, set the crossover point to maximum.**

2. High Level Inputs

If preamplifier outputs are not available, use the high-level (speaker) inputs. The speaker level inputs can be connected directly to the amplifier by inserting the speaker wire.

3. High Level Outputs

There are also high level outputs which can be used to connect to main speakers or to another powered subwoofer with high level inputs. **Note: High level outputs are paralleled to the high level inputs with no high pass filter.**

4. Crossover Frequency Control:

Continuously variable from 40 Hz to 140 Hz at 12 dB/octave. Set the frequency control to where the audio does not sound "muddy", normally between 60-80 Hz. **Note: If a LFE mono output is connected set the crossover point to maximum.**

5. Gain Control:

Adjusts the output level of the subwoofer. Set the level to where the bass frequencies blend with the other speakers. **Note: Most people have a tendency to set the level too high, which makes the audio sound "boomy". Reducing the level can restore proper balance.**

6. Phase Switch:

Selectable between 0° and 180°. This assists subwoofer placement. The correct position will be the one that provides the most apparent bass output.

7. Power Switch (Auto On/Off):

When the power is in the auto position, the amplifier will automatically turn on when a signal is present. Note: In auto/off mode, the power on LED is always on (red), even when amp is in rest mode (off). The power LED will turn green when the unit is activated.

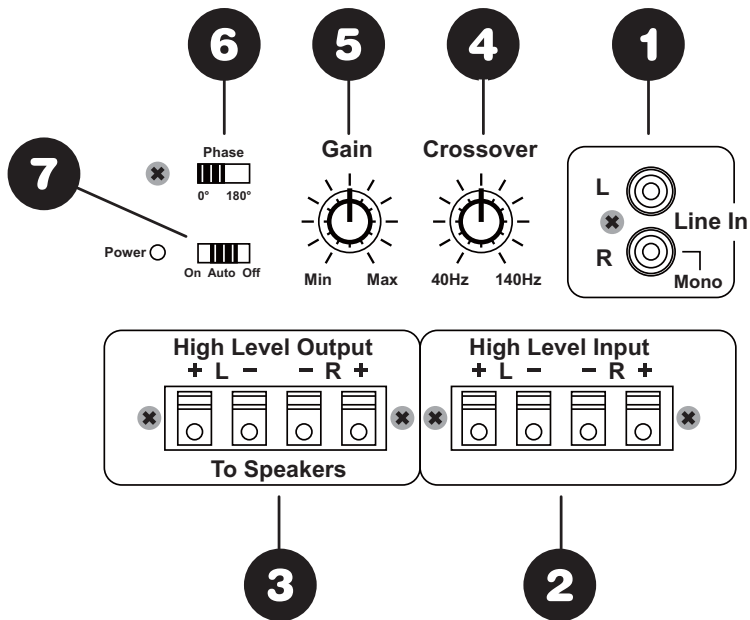

Room Placement

The SUB-1000L Subwoofer System will produce more bass when it is placed in a corner. Choose a corner that is close to the component area and place the sub at the front of the listening area. The included stand feet and anti-vibration strips can be used to stand the subwoofer on its side, and the included wall brackets can be used to install the subwoofer in a wall-mounted configuration, depending on space limitations. See diagram:

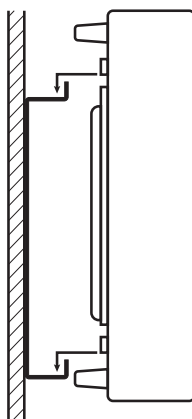
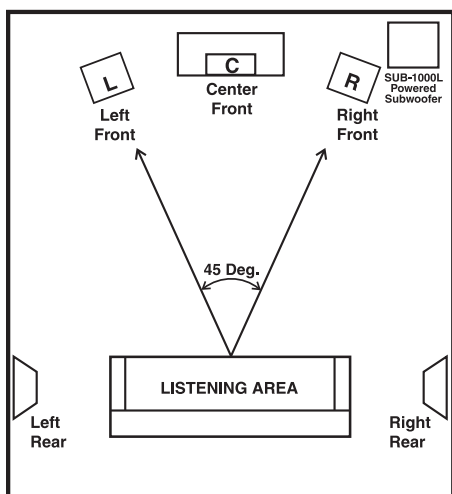

Wall Bracket Installation

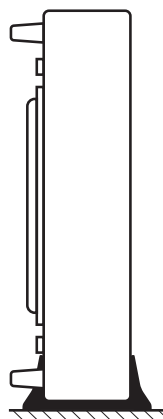

Vertical with Stand Feet



Resting on Floor

Specifications

Dimensions: 6" H x 25" W x 15-3/4" D

Frequency Response: 32 Hz-140 Hz

Woofers: 10" long throw

Amplifier Power: 100W

Voltage: 120 VAC / 60 Hz

Net weight: 28.5 lbs.

Warranty Information

Dayton Audio products are warranted free from defects in material and workmanship for **5 years** from date of purchase (see exceptions below). In the rare case of a product failure, please contact your place of purchase or call our Customer Support Department at (937) 743-8248.

Warranty Limitations

There are no other warranties, either express or implied, that extend the foregoing, and there are no warranties of merchantability or fitness for any particular purpose. Dayton Audio is not responsible for any consequential or inconsequential damage to any other unit or component or the cost for installation or extraction of any component of the audio system, or for the improper use of products. This includes but is not limited to burnt voice coils, overheating, bent frames, holes in the cone, or broken lead wires. Warranty does not apply to misuse, abuse, neglect, accident, improper use, etc. Dayton Audio reserves the right to repair or replace the products with either a new or factory refurbished unit.

Exception: Dayton Audio HDMI Cables -- No registration, no questions asked LIFETIME warranty. Replacement of Dayton Audio HDMI cables is with equal or better quality HDMI cables. Unassembled Kits - A 45-day return policy applies to unassembled kits. Once assembly has been started or completed, kits are deemed used and are nonreturnable for refund/exchange. This does not limit the manufacturers' warranty policies on any kit component.

This warranty gives you specific legal rights and you may also have other rights that vary from state to state.

Non-Warranty Service: If non-warranty service is required, the product may be sent to the Company for repair/replacement, transportation prepaid, by calling (937) 743-8248 for details, complete instructions, and service fee charges.



daytonaudio.com
tel + 937.743.8248
info@daytonaudio.com

705 Pleasant Valley Dr.
Springboro, OH 45066
USA

